



MORE INFO

MODERNO 5 PIZZE

Data Sheets - Scheda Tecnica



Weight Peso	156 kg 343 lbs	Materials Materiali	Stainless Steel, iron sheet, Ceramic fiber Acciaio inox, lamiera ferro, Fibroceramica
Cooking floor Piano Cottura	100x70 cm 40 x 28 in	Type of refractory Tipo di refrattario	Alumina silicate HeatKeeper™ Firebrick Tavella HeatKeeper™ silico-alluminoso
Max oven temperature Temperatura massima	500°C 1000°F	Recommended fuel Combustibile consigliato	WOOD - Max 2 in diam. logs. trimmings LEGNA - Ciochi diametro Max 5 cm potature
Heating time Minuti per scaldare	30'	Minimum flue draught Tiraggio minimo	11 Pa
Pizza capacity Numero Pizze	5 Ø30cm	Flue smokes mass flow Flusso volumetrico fumi	49.6 g/s
Rated charge Carica Nominale	8.3 kg/h 18.3 lbs/h	Average consumption Consumo Medio	5 kg/h 11 lbs/h
Smoke temperature Temperatura fumi	395°C 743°F	CO emission at 13% O₂ Emissioni CO al 13% O ₂	0.35% 4444 mg/Nm³



made in Italy

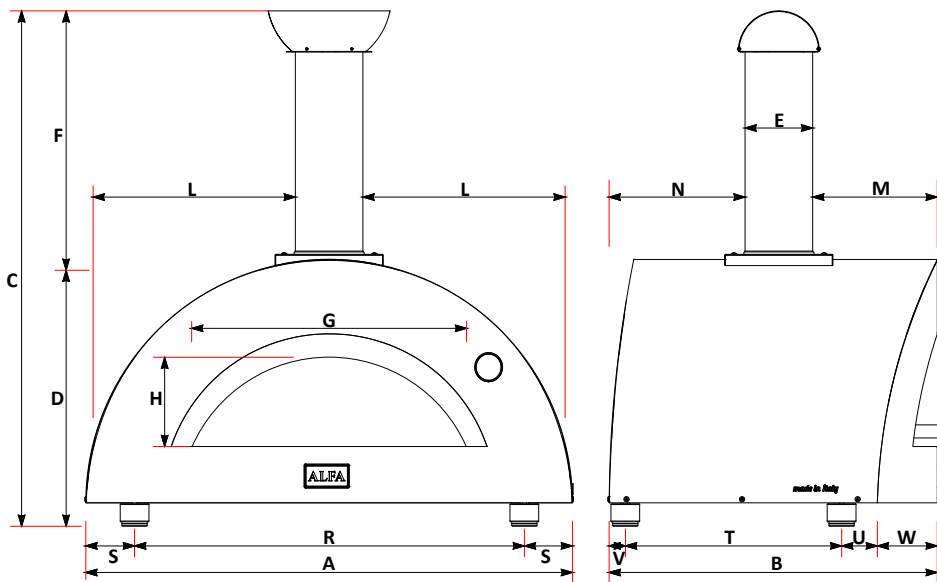

	cm	inch		cm	inch
A	118,3	46,6	N	60,5	23,8
B	102	40,2	O	69,5	27,4
C	149	58,7	P	32,5	12,8
D	64,7	25,5	Q	59,2	23,3
E	18	7	R	96	37,8
F	84,3	33,2	S	11,1	4,4
G	58	22,8	T	75	29,5
H	19,5	7,7	U	2,9	1,1
L	50,1	19,7	V	6,9	2,7
M	23,5	9,3	W	17,1	6,7

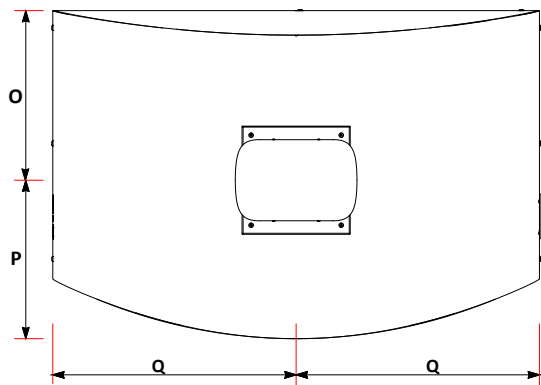

PACKAGING				
DIMENSIONE IMBALLO				
	Width Larghezza	Depth Profondità	Height Altezza	Weight Peso
cm	125,5	109,5	85	kg 179
inch	49.4	43.1	33.5	lbs 394,6

Description Descrizione	Code Codice
Chimney cap Comignolo	A S6PZ_01_025
Chimney Canna fumaria	B TI_180_750_SAT
Door Sportello	C S6PZ_01_021
Flange Flangia	D SML_03_0182
External shell Carter esterno	E SCRT-01-029
Thermometer Termometro	F YT63-190
Red bricks 30x20 cm Mattoni 30x20 cm	G RRA3020
Red bricks 40x20 cm Mattoni 40x20 cm	G RRA4020
Feet (n.4) Piedini	H SETPIE-M10X20
Logo Alfa (v1.0)	I D14PLAC-ALFA

